

by  
Alex Schwarz  
(VE7DXW)

# People involved in MDSR

- Phil Burk: Developer of JSyn (Java – 24-bit DSP)
- Alex Shovkopyas (VE3NEA): OmniRIG CAT Interface
- Guy Roels (ON6MU): MDSR-SA
- Adam Farson (VA7OJ): for the use of his test lab
- HAMS that helped to make the MDSR better:  
Maximo Barawid (DV2UXH) Brian Kassel (K7RE), Graham Le Good (G4GUN), Siegfried Jackstien (DG9BFC), Barry Bogart (VE7VIE), Kenneth S Stiles (KD0NQQO), Matthias Bopp (DD1US), David Shipman (VA7AM), Richard Illman (AE6EZ), Don Poaps (VA7DGP), Don Youngs (G3JIE), John R Sisler (KJ6ZL), Rajesh Nambiar (VU3VOC/AK4EC), William S. Bathgate (KD8IGK), Martin Storli (LA8OKA), Pete Juliano (N6QW), Brad Morris (KA3YAN), Luke Snow (KJ6NWE), Bill Bathgate (KD8IGK),

All the hundreds of Amateurs that bought and built the LIF and BiLiF kit.

**Thank you!!!**

# Why MDSR

- MDSR connects a professional grade transceiver to a 24-bit ADC at the IF level
- It provides an easy and affordable way to explore SDR technology
- It expands the capability of your existing analog transceiver
- It provides a platform to learn and experience hands on DSP processing

# The Sound Card and its ADC

## Why is a 24-bit sound card better than 16-bit?

- A 24-bit ADC provides ~16.8M quantization steps vs. 65536 in a 16-bit ADC
- When a 1V (+12dBm) signal is received the smallest step at 24-bit is 0.059 $\mu$ V, compared to 16-bit; 15.2 $\mu$ V = S5 (-96dBm).
- The higher quantization noise of a 16-bit ADC degrades its dynamic range vs. a 24-bit ADC.
- The usable dynamic range of a 24-bit ADC is ~ 130dB vs. (16-bit ~80dB)
- When strong signals are received, a higher dynamic range allows the operator to see the big signals as well as the weak ones. Due to its lower dynamic range, the 16-bit ADC in a typical on-board PC sound card will capture weak signals only if its headroom has not been consumed by strong signals.
- A high-grade (“professional”) external USB sound card with a 24-bit ADC will fully exploit the dynamic range possibilities of MDSR and is thus well worth the additional investment.
- These limitations are defined by physics, and can not be changed though programming.

# LIF and BiLIF Hardware

- LIF PCB  
available as kit
- Up-converter  
available as partial kit
- Easy to build  
no fancy tools are required

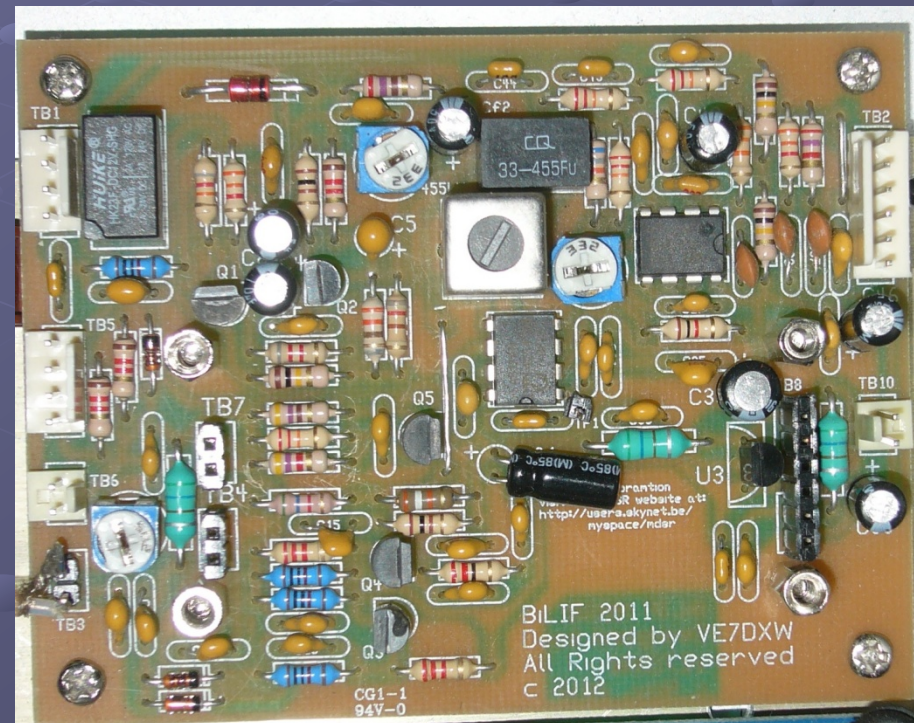
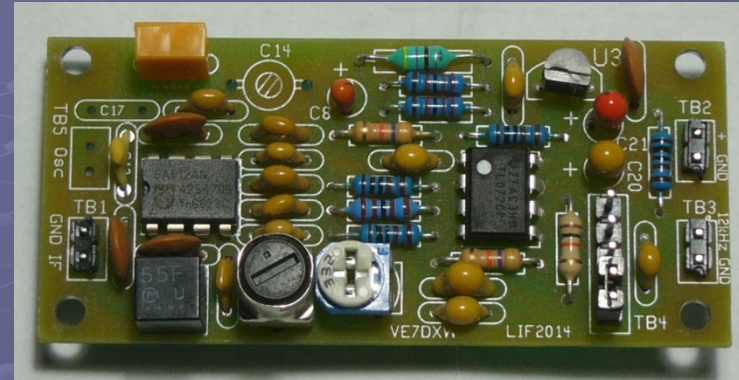

# LIF and BiLIF Hardware

- BiLIF PCB in Aluminum Enclosure

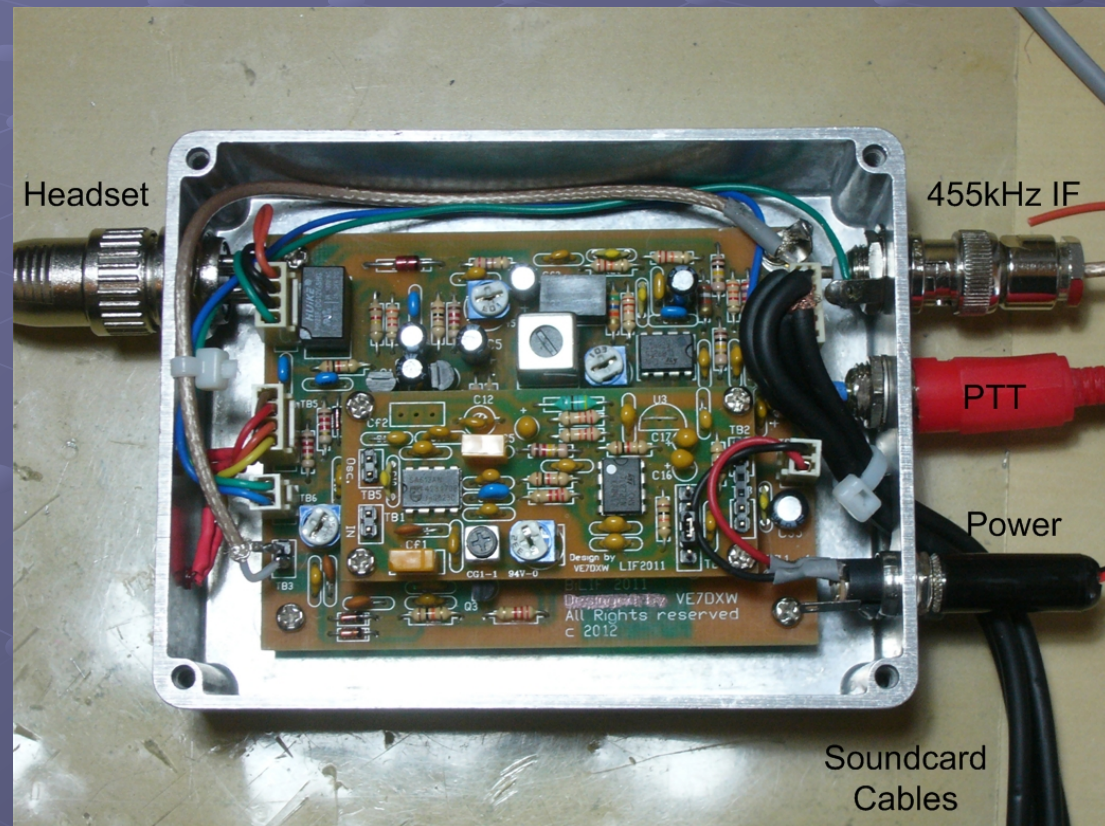

# LIF and BiLIF Hardware

- BiLIF with USB Sound Card  
Asus U7 true 24-bit

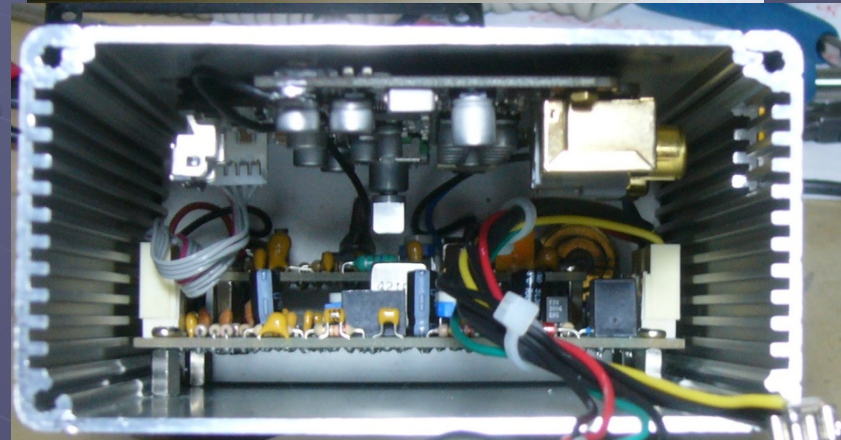
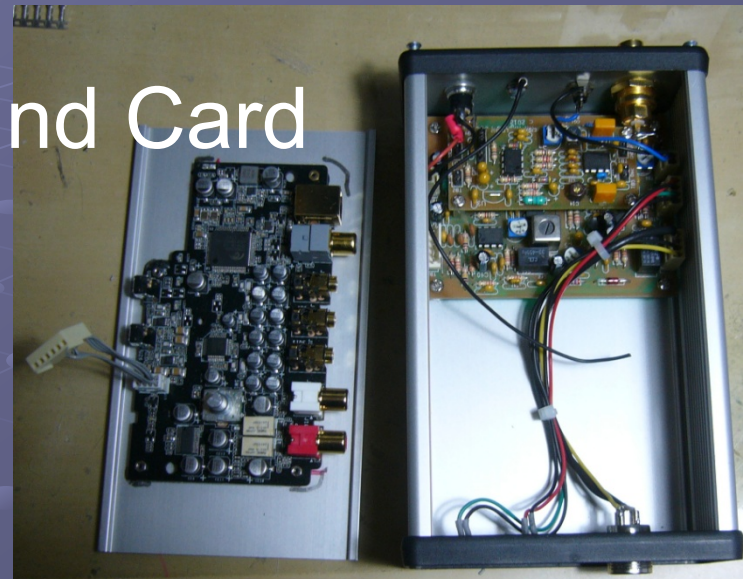

# Connecting the LIF to the Transceiver

The list of transceivers that are capable of supporting the LIF–MDSR interface is growing. Lots of work has been done by the HAM community and it is documented on the MDSRadio Yahoo user group (<http://groups.yahoo.com/group/mdsradio/>).

## 8 transceivers have been modified and documented by the MDSR Team.

- Installing a LIF port in the IC703.pdf
- Installing a LIF port in the IC7000.pdf
- Installing a LIF port the FT857 - 897.pdf
- Installing a LIF port in the FT817.pdf
- 12kHz port output Kenwood TS-2000.pdf
- Installing LIF port in a Yaesu FT-950 .pdf
- Installing LIF port in a IC-756.pdf

## Receivers / Scanners

- Installing LIF port in a BCD996P2.pdf
- Installing LIF port in a Panasonic RF4900/RF4800.pdf

- Available in our Yahoo support group only:

IC-7100, IC7200, IC-735, IC-746, IC-706, FT-736, TS-850 and many more interesting pictures and the latest information about current developments. **Register!**

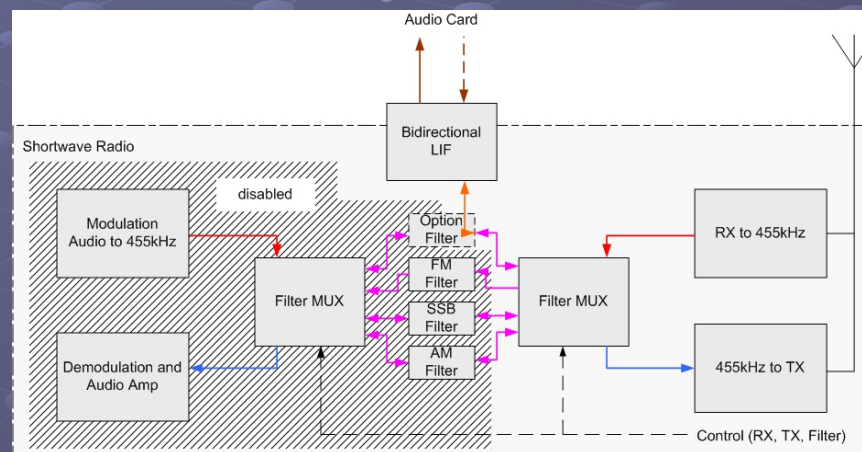



# Connecting the LIF and BiLIF to the Computer

The MDSR setup uses two audio cards. One (high-grade) is for the IF processing and the other is usually an on-board device for base audio. This configuration is easy adapted to digital-mode software such as fldigi, JT-65, WSPR and many others.

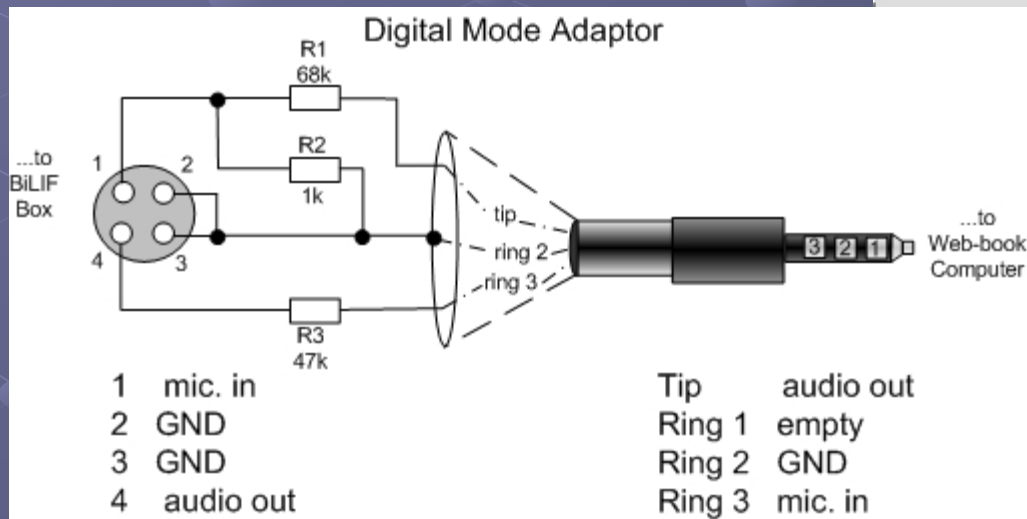
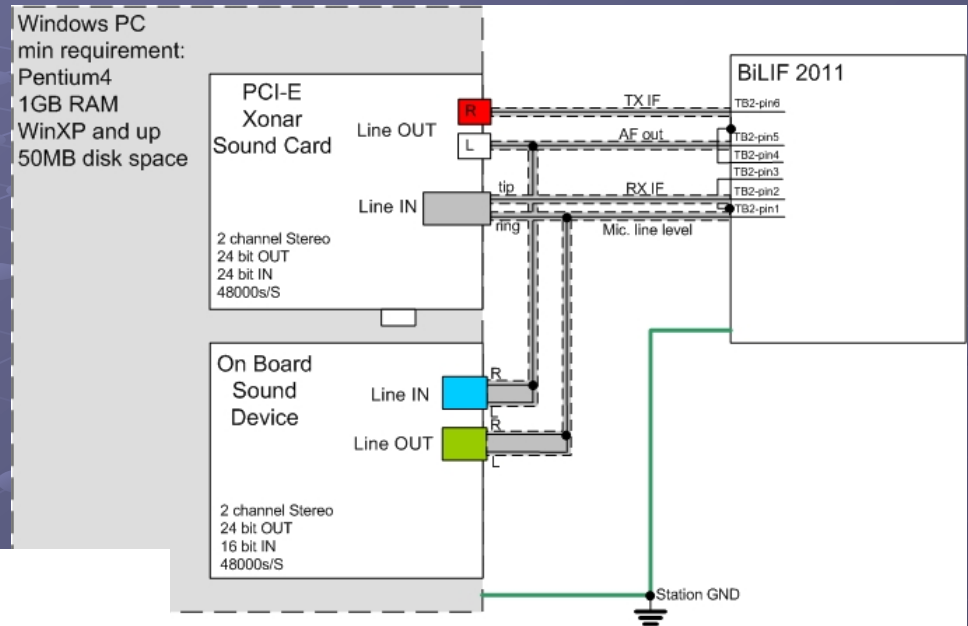

The setup with USB sound cards and Web books requires a special 1 tip – 3 ring plug for the connection to the onboard sound device.

# Web-book computer

- Asus Transformer Web-book computer
- Quad Atom Processor – 64GB
- 10h Battery life
- USB sound card can be powered by computer (reduces battery life)



# Mobile Setup (IC-7000)

- All units have to be able to accept 12V (operation and charging)
- Antenna system has to be light-weight and has to mount non-destructively
- Telescopic Antenna MFJ-1979 (resonant at 20m and up, 3/8 mount)
- For 80m and 40m additional coil was used
- During driving CR-8900 antenna for 10/6/2m and 70cm



# Portable setup (FT-817)

- All units have to be able to accept 12V (operation and charging)
- Antenna system has to be light weight and has to mount non-destructively
- Telescopic Antenna MFJ-1979 (resonant at 20m and up, 3/8 mount)
- For 80m and 40m an additional coil is used.

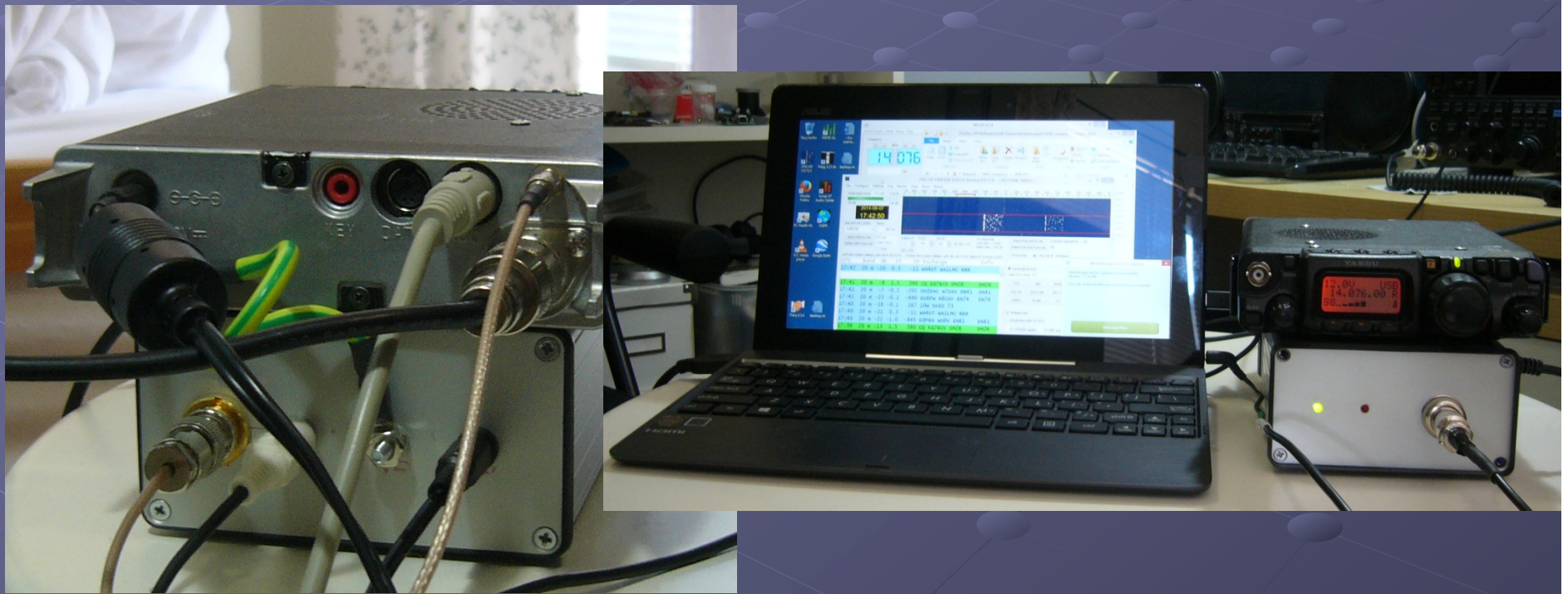

# MDSR V3.1 & New SA V1.3

- The MDSR V3.1 can be downloaded from the MDSR user group mod and demod of USB, LSB, CW, AM & DRM demod, 4 IF filter bandwidth, notch filter, post audio noise filters, remote control via Internet, TX audio processing, OmniRig CAT interface, spectrum analyzer, waterfall, download includes VLAN, fldigi, compatible with most popular digital modulation software such as WSPR and WSJT-X, easy to set up and calibrate, full manuals.
  - MDSR 3.1 integrates the Java SA V1.3 by providing frequency and band information.
  - There is also a button to start the Java SA from within the MDSR software.
  - Improvements on the remote feature.
  - Just released SA V1.3 provides mouse support and includes a RF-Seismograph to monitor signal strength over a long period of time, currently 24h is the data limit. After the limit is reached the oldest data point is lost and display scrolls
- Future developments: write data to a file and automate, display reoccurring daily data in one graph, provide a scanning feature to record several different bands at once.

# Spectrum Analyzer V1.3

The Java Spectrum analyzer connects to the MDSR to provide frequency, intensity and bandpass information.

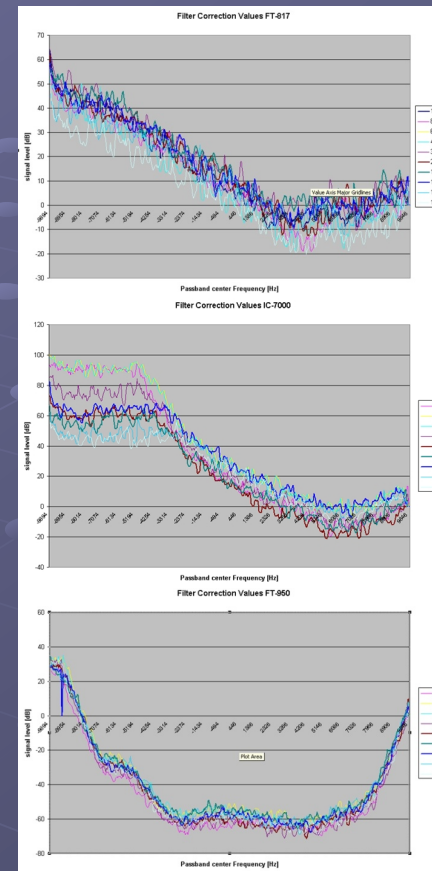
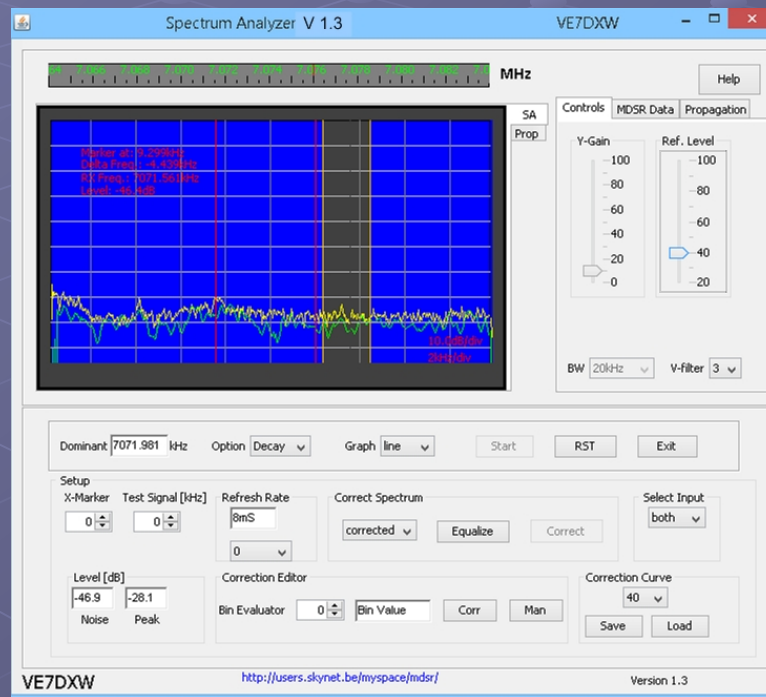

On the left: the “Spectral Amplitude Correction” curves for the FT-817, IC-7000 and the FT-817.

# Java Spectrum Analyzer V1.3

The RF-Seismograph displays a RF intensity/time scan that reveals band openings and solar activity.

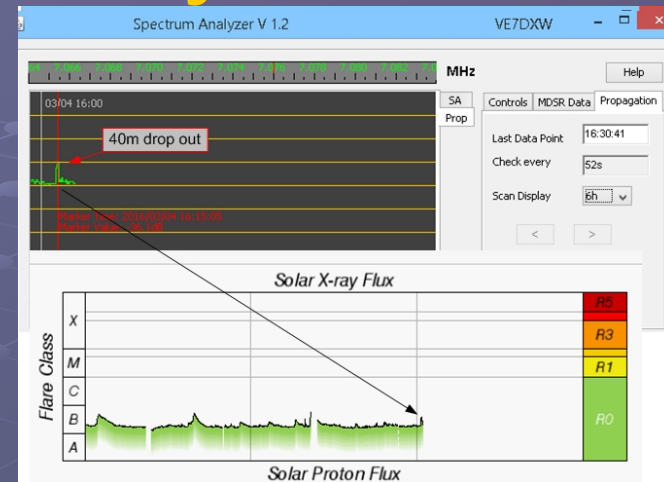
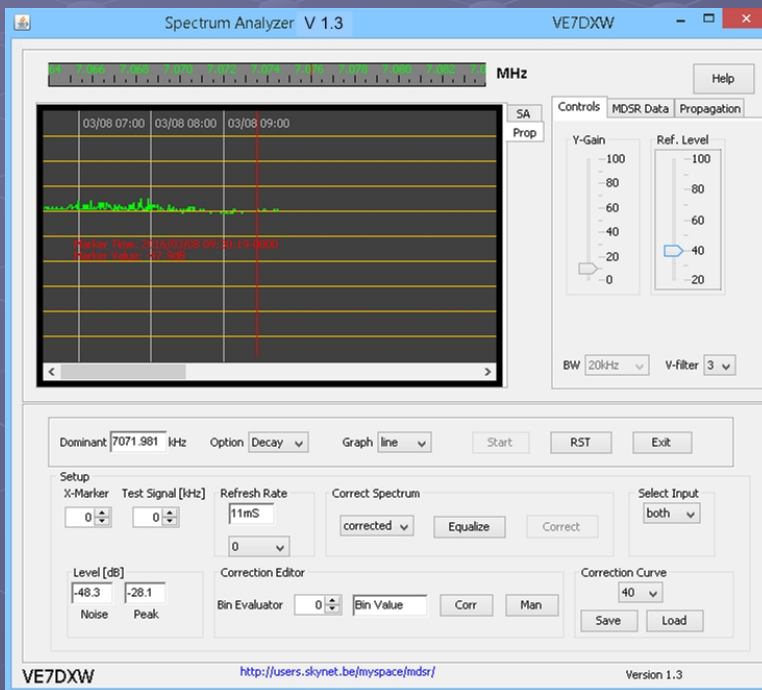

On the left: detection of solar flare and a rare 40m 3AM PST band opening.

# Questions?

## Contact information:

Alex Schwarz: [alexschwarz@telus.net](mailto:alexschwarz@telus.net)

Website: [users.skynet.be/myspace/mdsr](http://users.skynet.be/myspace/mdsr)

Yahoo user group: [groups.yahoo.com/group/mdsradio/](http://groups.yahoo.com/group/mdsradio/)

Thank you for your interest and participation  
in this presentation

Kits will be available in the demo room

© 2016